



SENIOR THESIS PROPOSAL

S.T.E.P.S. Building

Lehigh University

Bethlehem, PA

Joseph S. Murray, Structural Option

Faculty Advisor: Linda Hanagan

December 14, 2012

Table of Contents

Executive Summary	2
Building Introduction	3
Structural System	7
Floor System	6
Vertical Members	8
Foundation	8
Roof System	9
Lateral System	10
Problem Statement	12
Problem Solution	12
Proposed Breadths	15
Tasks & Tools	16
Proposed Schedule	17
Conclusion	18
A-1 Existing Structural and Architectural Floor Plans	19

Executive Summary

The S.T.E.P.S. Building in Bethlehem, PA sits on Lehigh University's campus. It is a mixed use facility consisting of laboratories, lecture halls, and faculty offices. The building is divided into two main wings which are bridged by a central atrium.

The structural system of the building consists of semi-rigid moment frames and full moment frames. It uses a composite floor as a rigid diaphragm to transfer lateral loads imposed on the façade to the beams and girders. The beams and girders then transfer these loads through their moment connections to a network of mainly W14 columns. The columns finally transfer the load into the soil through a combination of spread footings and mat foundations.

The proposed structural breadth consists of three major tasks. First, the semi-rigid wind clips will be replaced with braced framed and full moment connections. Second, the floor system will be checked against vibration control tolerances and redesigned as necessary. Third, any suspicious locations which may produce conflicts in steel erection will be examined and redesigned.

The two proposed breadths are related to architectural and construction management considerations. As a consequence of adding braced frames at certain location, an architectural study of the braces will be undertaken. Any potential conflicts should be resolved with respect to head room and pedestrian pathways through the building. The construction management breadth consists of a detailed construction sequence with crane positioning. An examination of the possibility of prefabricating and shop welding as much as possible will also be undertaken to see potential cost savings from the reduction in field welds and erection time.

A proposed schedule is provided which has four milestone dates. These milestones are:

1. 1/28/13 Redesign lateral system and floor system
2. 2/11/13 Finalize computer model
3. 3/1/13 Analyze foundation and connections
4. 3/25/13 Complete research and analysis of breadth topics

Building Introduction

Lehigh University envisioned the Science, Technology, Environment, Policy, and Society (S.T.E.P.S.) Building as a way to attract new students and retain existing students in the science and engineering fields. A picture of the building is in Figure 1. The university lacked a modern laboratory building with all the amenities that have come with increases in technology over the years. In an interesting and experimental fashion, the departments have been intermixed by Health, Education & Research Association, Inc. They believe it will lead to increased communication and collaboration among faculty and researchers of various disciplines.

Figure 1: South Façade



Image Courtesy of Lehigh University

Senior thesis proposal

Joseph S. Murray

The building is oriented on the corner of East Packer Ave. and Vine St. as shown in Figure 2. The streets do not intersect at a 90 degree angle. The architects decided to use site lines to orient the building, which led to the nonlinear shape of the façade along Vine St.

Figure 2: Site Plan



Image Courtesy of BCJ Architects

Lehigh University slowly purchased the properties which were on the building site as they planned for a building to be put there. The location was ideal for expanding campus activities close to the campus core. This is shown in Lehigh's Campus Master Plan of 2000 in Figure 2.

Senior thesis proposal

Joseph S. Murray

Figure 2: Campus Master Plan

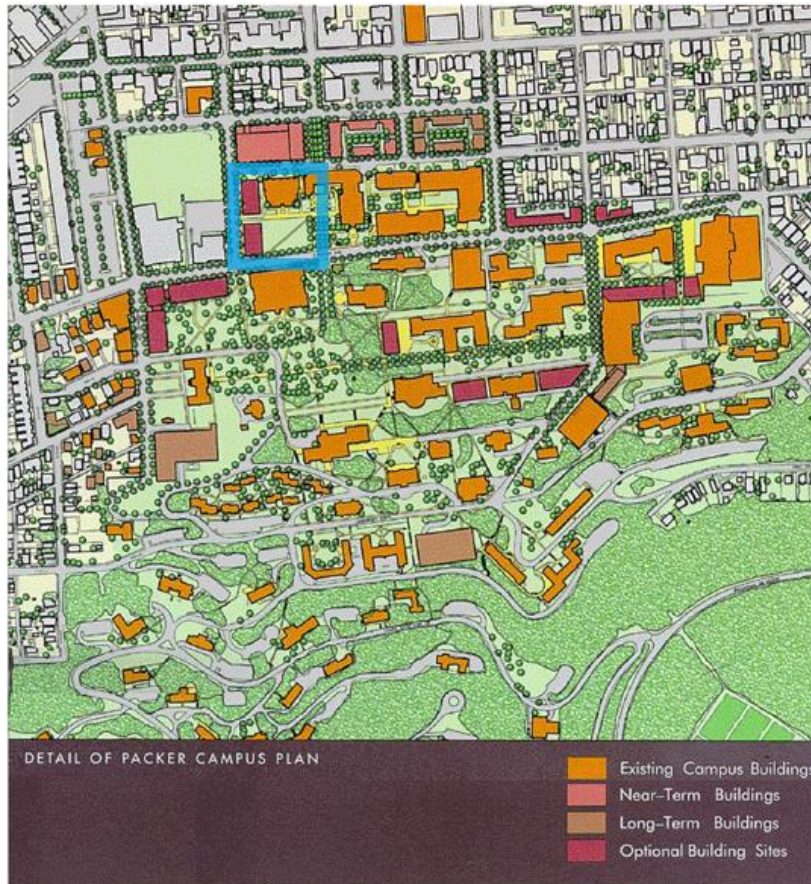

Image Courtesy of Lehigh University

The building is also connected to an existing structure through the use of a raised pathway that is enclosed. This further encourages interconnectivity between faculty, researchers, and students, because the adjoining building contains part of the College of Social Sciences. Between this adjacent building and S.T.E.P.S., there is a large open lawn. The university made a significant effort to maintain this lawn for extracurricular activities such as frisbee, croquet, and football. The S.T.E.P.S. Building is divided into three wings for the purpose of this analysis. These wings are diagramed in Figure 3.

Senior thesis proposal

Joseph S. Murray

Figure 3: Wings A, B, and C of S.T.E.P.S. Building



Image courtesy of Bing.com

Wing A is a one story structure with a lounge and entryway. It has raised clearstories to allow for natural daylight to illuminate the space. It also has a 12" deep green roof supported by structural wood which helped in earning LEED Certification. The building is LEED Gold certified by the United States Green Building Council (USGBC). Because of its limited building height, Wing A will not be analyzed in this report.

Wing B is a four story steel framed structure oriented along Packer Ave. There is a large atrium with lounge areas connecting Wing B to Wing C on each floor. Wing C is also steel framed and is 5 stories.

The gravity and lateral load resisting elements continue uninterrupted through the atrium. As a result, Wing B and Wing C will be treated as one building. The building's lateral system consists of moment connections between columns and beams throughout the building.

Sustainable features of the building include the green roof, high-efficiency glazing, sun shading, and custom mechanical systems.

Structural System

Figure 4: Typical Building Floor Plan

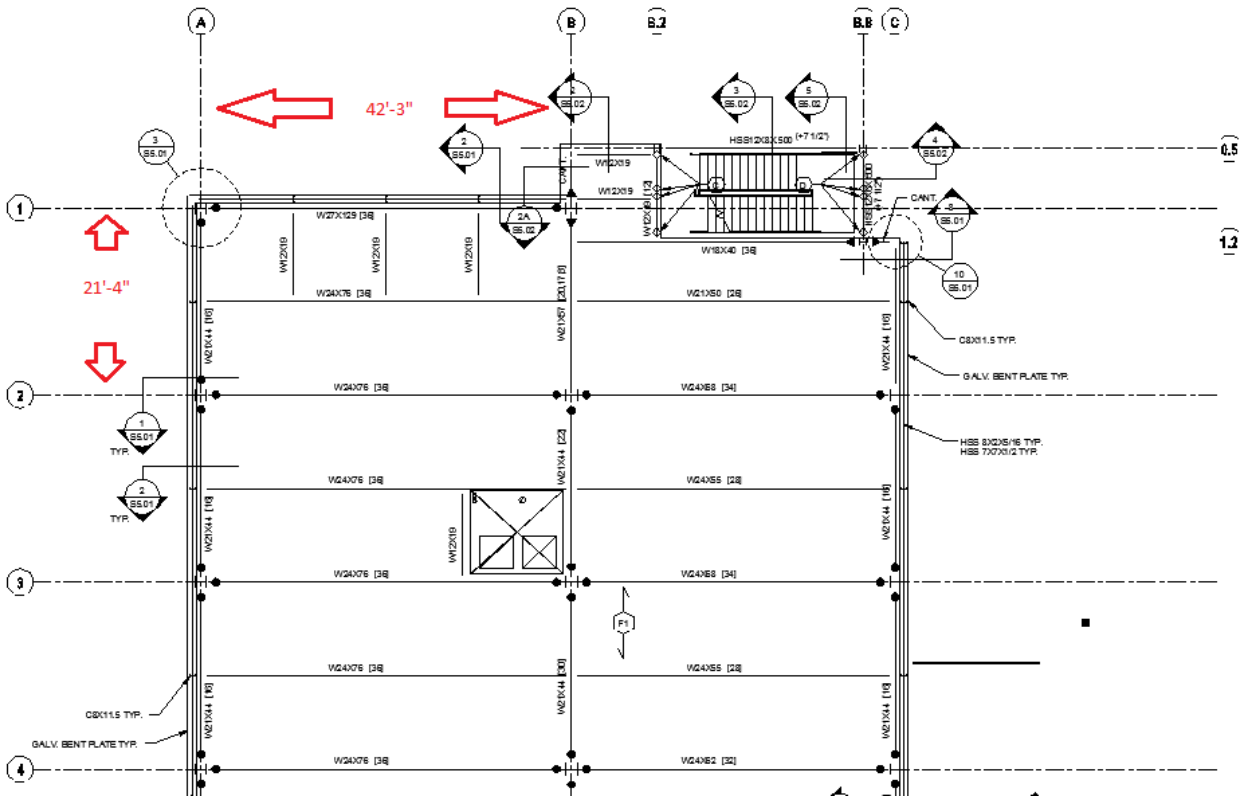

For a full floor plan, see Appendix A-1.

Floor System

There is a composite steel deck floor system in place for all floors in Wings B & C above grade. Basement floors are slab on grade.

Along Vine St., which will be considered the longitudinal direction of the building, typical girders have a center to center span of 21'-4" with one intersecting beam at their midpoint. The transverse beams which run parallel to Packer Ave. have a span anywhere from 36'-11" to 42'8".

The decking is a 3" deep 18 gauge steel deck with 4-1/2" normal weight concrete topping and welded wire fabric. The bulk of the decking is run longitudinally throughout Wings B & C and has a span of 10'8" between beam centerlines. The exceptions to this are two bays to the very south of Wing B along Packer Ave. These bays are oriented transversely. The total thickness ends up being 7-1/2" with a 6x6" W2.9 x

Senior thesis proposal

Joseph S. Murray

W2.9 welded wire fabric embedded $\frac{3}{4}$ " from the top of the slab. Figure 5 shows a typical detail of the composite floor decking.

Figure 5: Composite Floor Deck Detail

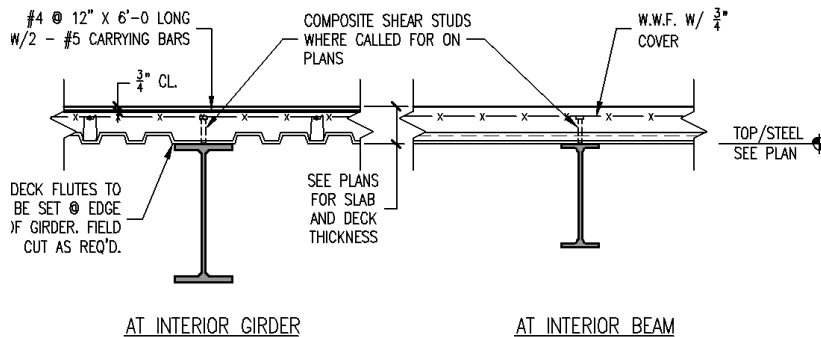

K COMPOSITE FLOOR DECK DETAILS

NOTE: PROVIDE DIAGONAL #5 X 6'-0" LONG AT RE-ENTRANT CORNERS CENTER BAR ON CORNER

The floor system is supported by wide flange beams designed as simply supported. A combination of full moment connections, semi-rigid moment connections, and shear connections are used. Typical sizes for transverse beams are W24x55 and W24x76. The girders are W21x44. Most beams have between 28 and 36 studs to transfer shear. Figure 5 shows a typical Full Moment Connection with field welds noted. Figure 6 shows the entirety of the first floor system for Wing B. Figure 8 shows the entirety of the first floor system for Wing C.

Vertical Members

Wide flange columns are used throughout the building for gravity loads. They are arranged for strong axis bending in the transverse direction. Most spans have a column at either end with another at the midpoint.

W14 is the most common section size with weights varying from W14x90 all the way up to W14x192 on the lower floors.

Foundation

Schnabel Engineering performed a geotechnical analysis of the site in 2007. This concluded that the soil had sufficient bearing capacity to support the loads from the building.

Interior columns are supported by a mat foundation 18' wide and 3'-6" deep shown in Figure 6 and Figure 7. Exterior columns bear on square footings ranging from 11'x11' to 16'x16' with depths from 1'6" to 2'. These are tied into the foundation by base plates with concrete piers.

Senior thesis proposal

Joseph S. Murray

Figure 6: Mat Foundation Plan View

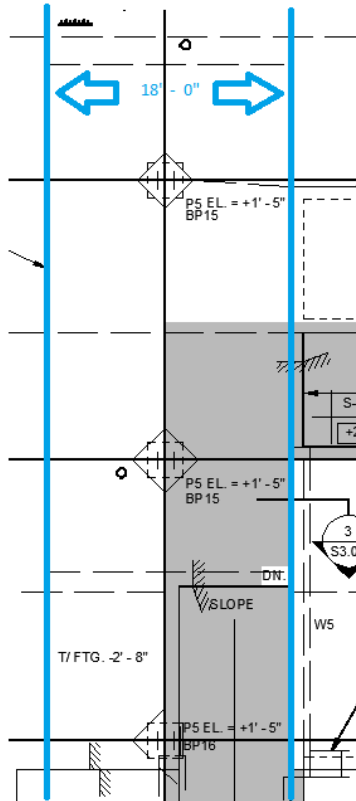

Figure 7: Mat Footing Schedule

MF1	* X 18'-0" X 3'-6"	#9 @ 12" O.C. E.W. BTM #9 @ 12" O.C. LONG, TOP #7 @ 12" O.C. TRANS, TOP	SEE PLAN FOR LENGTH
-----	--------------------	---	---------------------

The reinforced foundation walls have strip footings ranging from 2' to 6' wide with depths between 1' and 2'. These are monolithically cast with the piers for the exterior columns.

Roof System

The roof decking consists of a 3" 16 gauge steel roof deck with a sloped roof for drainage. Topping ranges from 1/4" to 4-1/2" to achieve a 1/4":1' slope. Therefore, total thickness ranges from 3-1/4" to 7-1/2". Framing is similar to floor framing with wide flanges ranging from W24x55 to W24x68.

Senior thesis proposal

Joseph S. Murray

The floor system has increased loads where the mechanical penthouses are situated. The penthouse itself is framed with square HSS tubing. Heavier W27x84 wide flange beams support this area.

Lateral System

The building resists lateral loads by moment connections at the beam to column locations. They are continuous throughout the building and beams are designed as simply supported for gravity loads. The moment connections are designed only to take lateral loads. A typical semi-rigid moment connection is shown in Figure 8. Many of these moment connections are semi-rigid connections to give the system more flexibility. An example of layout of the two types of moment connections in the floor plan is shown below in Figure 9. The triangles are full moment connections and the dots are semi-rigid.

Figure 8: Typical Semi-Rigid Moment Connection

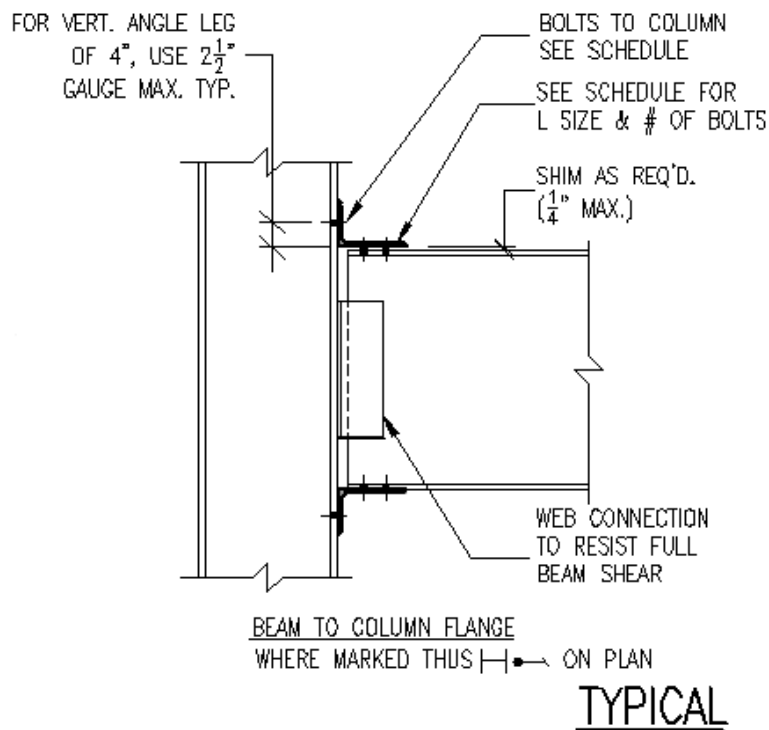
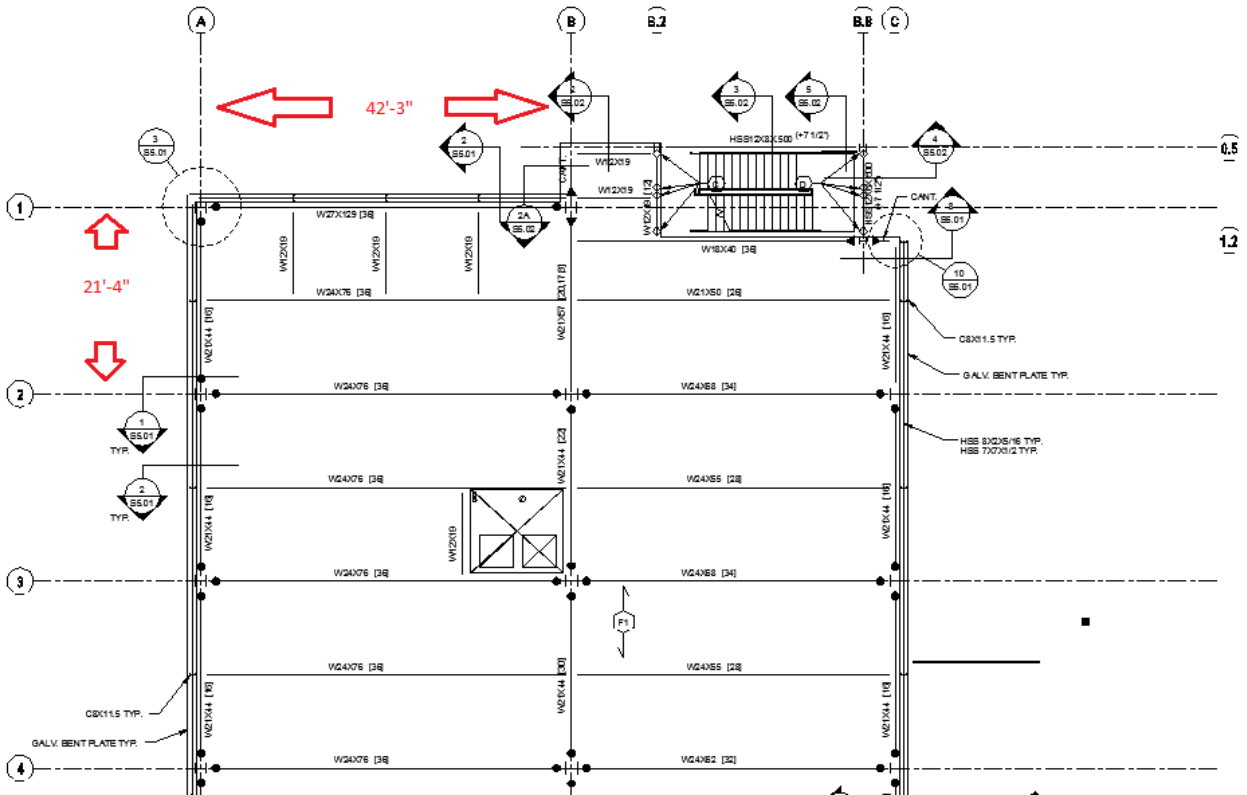

Figure 9: Typical floor plan with bay sizes



The lateral loads seen in the Penthouse are going to be the greatest based on height. At the highest Penthouse roof level, there are moment connections in the transverse direction and single angle braced frames in the longitudinal direction. The connections to the roof of the building are rigidly connected to the roof framing members. These members then transfer the load to flexible moment connections in the columns supporting the roof. These roof members are a larger W27x102 compared to adjacent members such as W24x68 or W27x84.

Problem Statement

The structural system of the S.T.E.P.S. building has been proven to be adequate for strength and serviceability requirements in Technical Reports 1, 2, and 3. The lateral force resisting system is almost entirely composed of semi-rigid wind clips throughout the building which are not designed for full moment capacity. Although earthquake forces do not control design for S.T.E.P.S., these wind clip connections have questionable reliability in the event of a seismic event. The floor system was designed for floor vibrations typical of a laboratory, although this has not been confirmed through analysis. The floor typically consists of W21 girders with a 7" deep concrete composite decking. W24's typically frame into the girders, which could result in some construction issues during erection with respect to connections.

Problem Solution

In order to design an effective alternative to the existing lateral system, the wind clips will be replaced with braced frames in the transverse direction of the building and full moment frames in the longitudinal direction. These types of lateral systems when designed correctly can perform just as well or better than the wind clips, especially in the case of a seismic event. Figure 9 has the floor plan revisions for Wing B, and Figure 10 has the floor plan revisions for Wing C. The braced frames are shown as red lines, and the moment frames are shown as blue triangles. All semi-rigid connections, currently marked as black dots, will be changed to shear or full moment connections as appropriate.

Vibration control tolerances will be researched, and the existing floor system will be analyzed for its performance in eliminating unnecessary floor vibrations. A standard peak velocity for other university laboratory buildings of $2000 \alpha"/s$ will be used as a criterion. Alternative floor systems will be investigated and analyzed as appropriate according to the acceptable vibrations allowed in a laboratory setting. If any of these alternate floor systems have distinct advantages over the existing floor, the floor system will be redesigned.

The braced frames which will be replacing the lateral system will be designed in complete detail including gusset plate connections to the beams and columns. The new typical full moment connections will also be looked at in detail. Spot checks will be made of any suspicious locations where two joining elements may produce an issue in erection. These connections will be redesigned as necessary using tools and techniques learned in AE 534, and a comparison between the existing system and proposed system will be made.

Senior thesis proposal

Joseph S. Murray

Figure 9: Revised Structural Floor Plan for Wing B

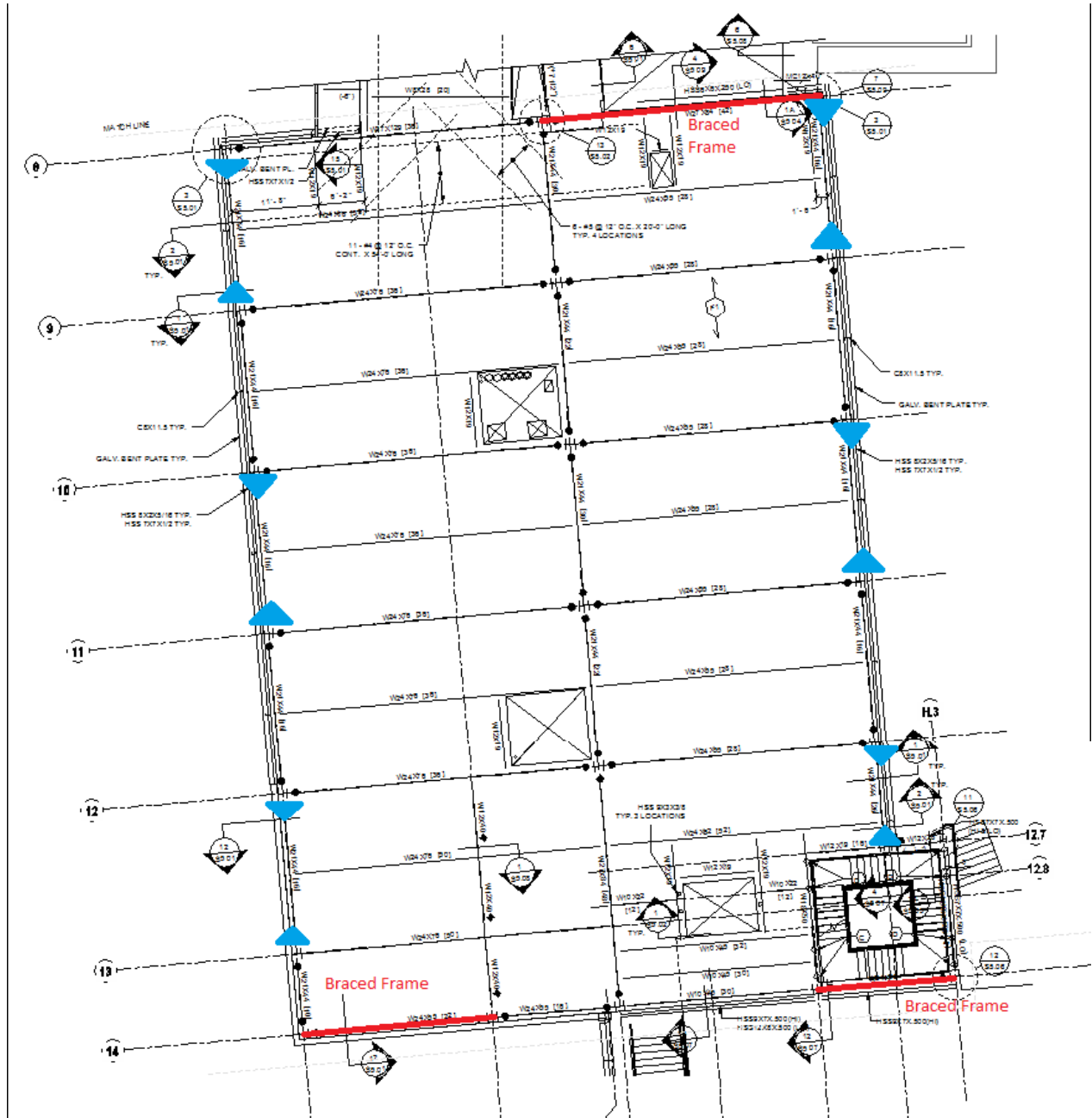

Breadth 1: Electrical

Electrical equipment is an essential part of any educational and research facility like S.T.E.P.S. Some of the necessary machines and processes require unique electrical loads that must be anticipated. The design loads will be calculated for the electrical system, and then they will be compared to the current system for potential modification. This includes any emergency lighting and fire alarm systems required by code for means of egress.

Breadth 2: Construction Management

Changing the connections in the building has an impact on erection sequencing, so a detailed construction sequence will be undertaken along with crane positioning for the project. With two busy intersections on the corner of the site and the close proximity of other structures, management of the location of the crane throughout construction is important and should be investigated. A site layout plan will be designed to fully understand optimal positioning of the crane and coordination among trades. The entire construction sequence will be assessed to examine whether this will produce a reduction in the time of construction. Other trades may be able to begin and finish their work quicker if steel erection time is reduced. The new construction sequence will be compared with the actual time of erection for any direct economic impact on the project. In addition, the impact of the new and existing connections on prefabrication and field welding will be examined. Working with a steel fabricator to prefabricate connections and shop weld as much as possible could have cost savings in the reduction of the schedule and eliminate some of the existing field welds.

Tasks & Tools

Depth:

1. Research will be done to determine how typical vibration tolerances in a laboratory building are used to design and analyze an appropriate floor system.
 - a. Design will be based on publications such as the AISC Steel Design Guide Series 11, ASHRAE Chapter 47, and the NIH General Design Guidelines Section 4.E.3.7.1.
2. After the new floor system is determined, a computer model will be made to determine the forces that need to be resisted by the structural system. Spot checks by hand will double check these results.
 - a. RAM Structural System will be used to model the new floor system and determine gravity and lateral loadings.
 - b. ASCE 7-10 will be used for lateral loads and IBC 2009 will be used for dead and live loads. AISC 14th Edition will be used for analysis of the structural system.
3. The lateral system will be redesigned with braced frames and full moment connections.
 - a. Skills used in AE 534 will be used to fully design the steel connections for optimized strength and constructability.

Breadths:

1. The building electrical loads will be calculated and the electrical system will be sized accordingly. This system will then be compared with the existing system.
 - a. The NEC 2008 and the listed equipment on the construction specifications will be used to determine electrical loads. Panelboards, wiring, and conduit will be sized according to skills learned in AE 311.
 - b. The IBC 2009 and the NEFC 2009 will be used to design fire alarms and emergency lighting along means of egress according to code.
2. Practicability and constructability of steel connections will be investigated. A schedule and cost analysis will then be performed and compared with the actual project. Crane positioning and construction sequencing will be analyzed to allow the best coordination of trades.
 - a. Microsoft Project and R.S. Means will be used to determine the schedule and cost of steel connections on the project.
 - b. Crane positioning and sequencing will be looked at using several plan views of the construction site throughout the construction process.

Proposed Schedule

Task	Start Date	End Date	Notes
Joseph S. Murray	Jan-7-13	Jan-14-13	Revise proposal
Structural Option	Jan-21-13	Jan-28-13	1/28/2013 Mileston
Redesign lateral system	Jan-21-13	Jan-28-13	Design full moment connections and braced frames
Research floor vibration	Jan-21-13	Jan-28-13	Research floor vibration
Redesign floor system for to limit vibration	Jan-21-13	Jan-28-13	Create RAM Model
Linda Hanagan	Feb-4-13	Feb-11-13	2/11/2013 Milestone 2
Analyze steel connections for constructability	Feb-4-13	Feb-11-13	Check building torsion, story drift, and overturning
Impact on Foundations	Feb-4-13	Feb-11-13	Spread Footing Calculations
S.T.E.P.S. Building	Feb-18-13	Feb-25-13	3/1/2013 Milestone 3
Research Breadth Topics	Feb-18-13	Feb-25-13	Calculate electrical demands for the building for comparison to the existing system
Spring Break	Mar-4-13	Mar-11-13	
Construction sequence and cost analysis of connection alterations	Mar-11-13	Mar-18-13	Compile Report and create Final Presentation
Finalize Report	Mar-11-13	Mar-18-13	
Final Report April 3rd	Mar-11-13	Mar-18-13	
3/25/2013 Mileston	Mar-11-13	Mar-18-13	
Faculty Jury Presentations April 9th-13th	Mar-11-13	Mar-18-13	
Jury Presentatio	Mar-11-13	Mar-18-13	
ABET Assessment and Update OFEP	Mar-11-13	Mar-18-13	
Senior Banquet April 26	Mar-11-13	Mar-18-13	
Milestones			
1	Redesigned lateral system and floor system for vibration control		
2	RAM model finalized with only minor details left		
3	Foundation analysis finalized and complete. Connections spot checked for constructability.		
4	Completed analysis and research for breadth topics		

Senior thesis proposal

Joseph S. Murray

Conclusion

Next semester, a thorough undertaking will examine the proposed changes to the lateral system, floor system, and steel connections. A new computer model will need to be produced to analyze the changes in the structure's behavior. Research will be done on the impact of floor vibrations in a laboratory setting and ways to dampen vibratory effects from building elements like corridors or cantilevered areas. Skills learned in AE 534 will be used to look at connections on the building and possibly redesign them for cost savings by reducing erection time.

The two breadths will also be investigated. Architecturally, the braces should be placed so they have as little impact architecturally as possible. However this is not always the case, and in the case of a conflict, there must be some resolution or compromise between the existing architecture and the proposed braced frames. From a construction management perspective, some research will need to be done into erection sequencing and crane positioning on the existing structure for comparison with the proposed changes. A comparison will also be made between the amount of prefabrication and shop welding indicated on the drawings. A possible reduction in field welding could result in cost savings.

All of this work will be done according to the proposed schedule on the previous page while reaching each milestone date with the associated work completed. This work will culminate in the completion of a final report by April 1, 2013 to allow ample time for preparation of the faculty jury presentations on April 9, 2013.

Senior thesis proposal

Joseph S. Murray

Appendix A-1

Figure 11: Floor Plan of Wing B

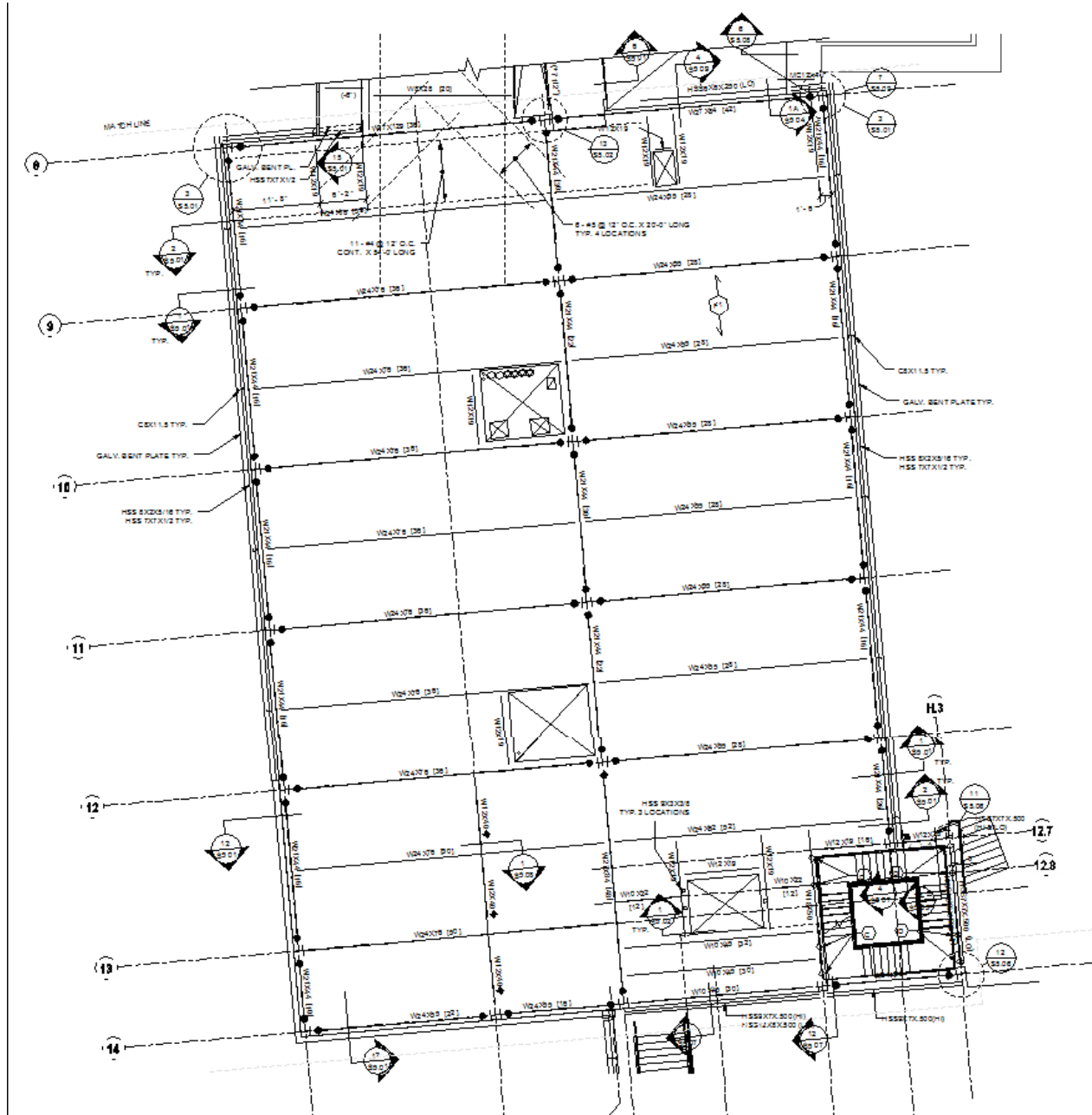
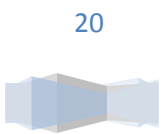
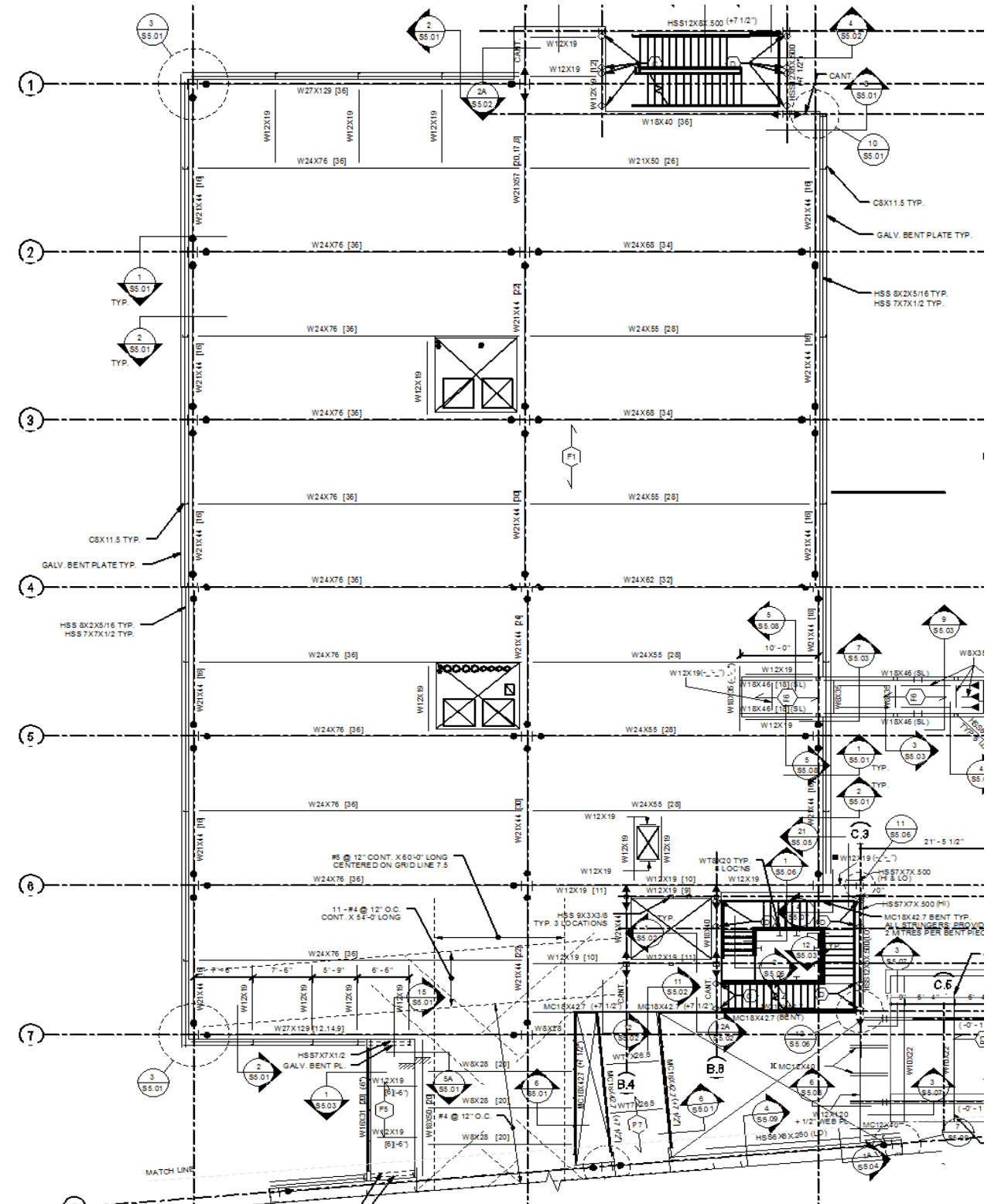

Figure 12: Floor Plan of Wing C



Senior thesis proposal

Joseph S. Murray

Figure 13: Typical Architectural Floor Plans



Courtesy BCJ Architects